

Central Processing Unit

Video BloX

ADEMCO Video's Central Processing Unit Module is the main processor for the VideoBloX crosspoint matrix switch, and contains the operating program and the system database in non-volatile memory that can retain critical data for up to one month without power. It is an embedded controller designed specifically for purpose of video and audio switching in a security environment and can initialize within seconds of power being applied.

Designed for security surveillance, the CPU module contains many features to ensure its reliability and availability. Watchdog timer and supply voltage monitoring ensures immediate restart in brown out conditions and the optional Arbitration Module supports dual CPU operation with automatic switchover. Installed in the matrix chassis, it occupies only a single 1/2U slot, which is smaller, more secure and more efficient than PC based switchers. Manufactured from stainless steel, the faceplate and rear termination panel provide a sophisticated look and improved grounding to reduce static problems.

The CPU is both powerful and versatile – powerful enough to switch up to 4,080 video/audio inputs to 256 video/audio outputs and versatile enough to provide complex switching and control in response to events, whether alarm initiated, scheduled or manually operated.

Installation and diagnostics are made easy by the availability of a CPU Video Port, which displays real-time information on any available monitor. Such readily available information assists the technician when troubleshooting system configuration problems.

FEATURES:

- High capacity – 4080 Inputs to 256 Outputs
- Multiple matrices – up to 15
- Up to 32 keyboards or networked workstations
- Embedded controller in high speed processor with non-volatile memory
- Low profile design – only 1/2U
- Supply voltage monitor and watchdog timer
- Powerful diagnostic monitoring tools
- Versatile, but simple, sequence engine for complex control
- Convenient rear panel connections for configuration PC, keyboards, alarm devices and other equipment



Front View

AVBCPU

ADEMCO
VIDEO

Central Processing Unit

Video BloX

FEATURES:

Open Protocol

VideoBloX provides an open protocol to allow the system to be connected and controlled by third party systems such as access control, building management and programmable logic control systems.

Sequence Engine

A powerful sequence engine enables the VideoBloX system to perform actions in response to events. The actions may be as simple as switching a specific camera to a specific monitor in response to an alarm input or as complex as the application requires. Events may be scheduled, initiated manually or initiated by alarm event and can have conditional statements associated with the process. With 1,024 sequences, each with 25 multiple parameter steps, some very complex functions may be created.

Groups and Scenes

Large capacity systems can become difficult for operators to manage. Groups and scenes provide the capability to simplify the use of the system, reducing operator training and increasing efficiency. Keyboard function keys are user defined as groups (of up to four cameras) each group comprised of multiple scenes. A scene is made up of specific views from four separate cameras or a combination of presets on a high speed dome. An operator can call a group and step through scenes with a minimum of keyboard actions.

Alarm and Relay Termination Panel

Each VideoBloX CPU is provided with an alarm and relay termination panel, which provides up to 32 Alarm Inputs and four

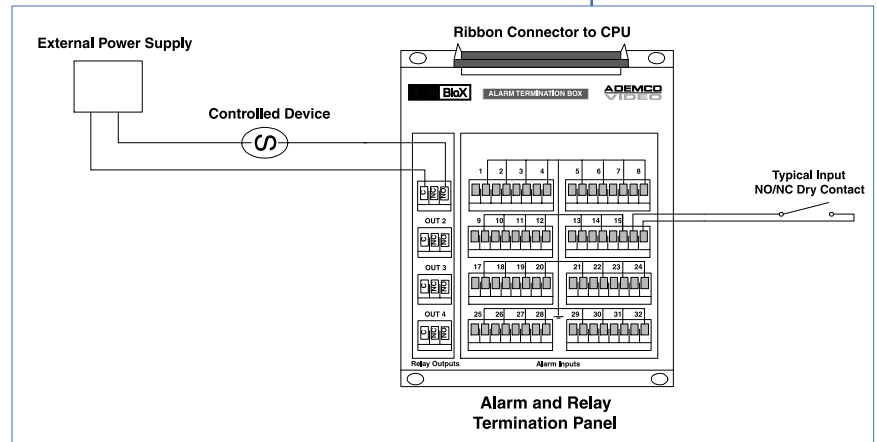

Form C relay outputs connected on removable terminal blocks. The alarms may be utilized as events for initiating sequence actions and relay outputs may be used as part of those sequence actions. The alarm input/control output capacity can be increased with the provision of optional I²C devices.

CPU Diagnostic Mode

The CPU can be connected to a standard composite video input monitor. With the use of pushbuttons mounted on the faceplate, it provides real-time diagnostic information to the technician. Information such as baud rates, integrity of video connection, current status of switched input to outputs, the real time status of connected alarm inputs, key-board status, sequences active and other information is of great diagnostic importance.

Redundant CPU

The addition of a second CPU and the arbitration module provides a "hot" back-up system. The arbitration module monitors the condition of the active CPU. If a problem is sensed, it automatically switches to the second CPU.

AVBCPU

SPECIFICATIONS:

- Rack Height:
CPU is 1/2U (0.875")
Arbitration Module is 1-1/2U (2.625")
- Operating Temperature: 0° to 40° C

ORDERING:

Part No.	Description
AVBCPU	VideoBloX embedded controller with high-speed processor
AVBARB	Arbitration Module to switch CPU's

ADEMCO VIDEO

Sales800-467-5875
Applications877-653-0302
Technical Support . .800-645-7492
Fax516-921-0491
Web site: www.ademcovideo.com

171 Eileen Way, Syosset, NY 11791

Copyright ©2002 Pittway Corporation

ADEMCO
VIDEO