

## HCD554IPX

### EQUIP™ SERIES TRUE DAY/NIGHT NETWORK CAMERA

Honeywell's EQUIP™ Series is an array of IP-based products that have an open architecture platform and utilise a single Application Program Interface (API). The API allows for a common user experience and integration with hybrid Digital Video Recorders (DVRs) and Network Video Recorders (NVRs).

The Honeywell HCD554IPX day/night network camera offers the latest in digital video surveillance. The 1/3" CCD network camera combines world-class imaging and camera technology with the EQUIP Series IP networking technology providing streaming MPEG-4 images in 4CIF, 2CIF, or CIF resolutions with rates up to 25 fps for PAL systems.

The HCD554IPX day/night camera adapts to varying lighting conditions to ensure the highest picture quality even in extreme low light conditions. When the light level drops too low for accurate video identification in colour, the camera moves the IR cut filter out of the optical path and then switches to black and white video to capture more detail using the increased sensitivity of the CCD to IR light. For additional control, the on-board alarm input can be configured to switch the camera from day to night mode to allow synchronisation with external lighting.

The HCD554IPX has built-in Power over Ethernet (IEEE 802.3af), which allows power to be supplied to the camera using the network, eliminating the need for a separate power supply and reducing the cost of installation. For additional installation flexibility the unit can also be powered with 12 VDC or 24 VAC.

#### Market Opportunities

The HCD554IPX is a network surveillance solution designed for object recognition that is required in locations where variable and low light conditions exist. Set-up is quick and easy and can be customised through a Web client or from an NVR. This provides optimum performance for both indoor and outdoor applications.

#### Features:

- 4CIF, 2CIF, or CIF resolutions
- 1/3" colour CCD, 540 TVL
- Excellent low light performance, down to 0.4 lux
- Camera Sabotage Detection
- MPEG-4 compression
- Remote firmware updates
- Supports both Dynamic and Static IP addresses
- Variable day/night threshold setting to accommodate switching to black and white images in low light
- Multiple levels of password protected remote access prevents unauthorised users from altering system settings
- Includes advanced IP locator software to make system set-up easy
- Web server for remote set-up of camera video and network parameters
- 12 VDC/24 VAC or PoE IEEE 802.3af choice of power inputs
- Supports CS mount lenses
- Supports two-way audio



## HCD554IPX

### SPECIFICATIONS

Like all cameras in the EQUIP Series, the HCD554IPX network camera uses Honeywell technology for camera sabotage detection, remote firmware updating and for secure storage of all camera settings. Camera sabotage detection notifies the user when a camera's field of view is altered, blinded or blurred. This ensures the video's integrity and alerts the customer to either a live event or a system problem that is causing disruption to the video stream. Honeywell's technology also allows users to remotely upload firmware to the camera. Set-up is quick and easy and can be customised through a Web client or from an NVR or DVR. The built-in Web server provides password protected access to the camera's video and network set-up.

#### System Diagram

##### Internet Explorer or Honeywell IT Utility

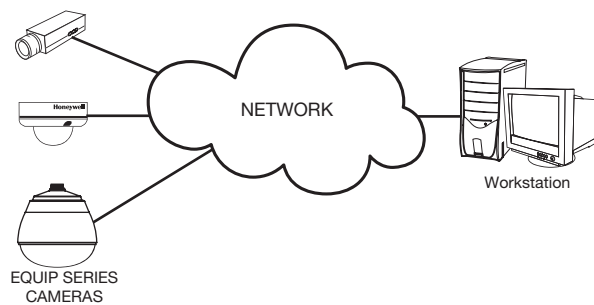

##### Hybrid DVR or NVR

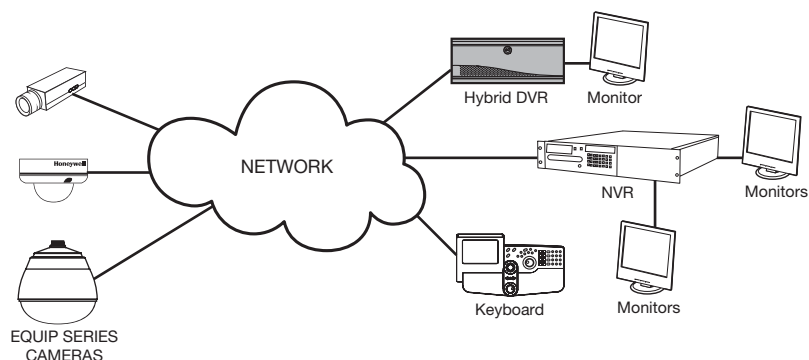

## HCD554IPX

### SPECIFICATIONS

Operational		
Video Standard	PAL	
Scanning System	625/50 lines (PAL)	
Image Sensor	1/3" CCD	
Number of Pixels (H x V)	752 x 582 (PAL)	
Minimum Illumination	0.6 lux colour/0.4 lux BW @ 50 IRE, F1.2 0.25 lux colour/0.15 lux BW @ 30 IRE, F1.2	
Horizontal Resolution	Greater than 540 TVL	
Automatic Lens Control	DC Iris Level 1-25	
Video Output	1.0 Vp-p @ 75 Ohms	
S/N Ratio	50 dB or more (AGC off)	
Auto Gain Control	Off/On, selectable (10-30 dB)	
Automatic Electronic Shutter	1/50-1/100,000 sec (PAL)	
White Balance	ATW, User Fixed, AWC (Auto or Manual), Fluorescent, MWB (Manual Mode), Indoor, Outdoor	
Back Light Compensation	Off/On, selectable	
Gamma	0.45	
Audio/Two-Way	Line in/out	
Electrical		
Input Voltage	12 VDC/24 VAC, PoE IEEE 802.3af	
Input Range	11-16 VDC, 17-28 VAC	
Surge Suppression	1.5 kW transient	
Power Consumption	8 W (max)	
Mechanical		
Dimensions (W x H x D)	See Diagram	
Weight	1.1 lb (.5 kg) camera only	
Construction	Housing: Aluminium Finish: Cool Grey Powder Coat	
Camera Mount	1/4-20 UNC mounting ring	
Lens Mount	CS Lens Mount	
Connector	Video Output: BNC connector Lens: 4 Pin Connector Power Input: Removable screw block Network: RJ45 connector Alarm I/O: Removable screw block Audio In: 3.5 mm mono phone jack Audio Out: 3.5 mm mono phone jack	
Environmental		
Temperature	Operating: 14°F to 122°F (-10°C to 50°C) Storage: -4°F to 140°F (-20°C to 60°C)	
Relative Humidity	0% to 85%, non-condensing	
IP Specifications		
Video Compression	MPEG-4 Part 2 (ISO/IEC 14496-2) SP level 0-3	
Resolutions	4CIF 2CIF CIF	PAL 704 x 576 704 x 288 352 x 288
Frame Rate PAL	Up to 25 fps video in all resolutions	
Video Streaming	MPEG-4 controllable frame rate and bandwidth. Constant or variable bit rate	
Security	Multiple user access levels with password protection	
Users	1 Administrator, 4 Guests (unicast)	
Video Access from Web Browser	Camera live view for up to 5 clients. Full control of all camera settings available to administrator	
Minimum Web Browsing Requirements	Pentium IV CPU 3.0 GHz or equivalent AMD, 512 MB RAM, AGP graphics card (32 MB RAM) Windows® XP 2000, Internet Explorer 6.0 or later	
Installation and Management Maintenance	Honeywell IP Utility software identifies the IP address, checks status of device	
Supported Protocols	IPv4, HTTP, TCP, RTSP, RTP, UDP, ARP, DNS, RTCP, FTP, ICMP, DHCP, Bonjour, IGMP	
Regulatory		
Emissions	FCC, CE (EN55013)	
Immunity	CE (EN50130-4)	
Safety	EU: 73/23/EEC LVD UL Listed (file E319174)	

# HCD554IPX

## SPECIFICATIONS

System Compatibility	
<b>Hybrid DVRs</b>	
Fusion III	Full Featured Hybrid Digital Video Recorder, version 3.6 or higher
<b>NVRs</b>	
Enterprise NVR Series	Enterprise Class Digital Network Video Recorder System, version 5.6 or higher
DVM	Digital Video Manager, version R200.2 or higher

Accessories	
<b>Recommended Lens Options</b>	
HLD29V8DNL	2.9-8 mm, F0.95, DC Auto Iris Lens, IR Corrected
HLD27V13DNL	2.7-13.5 mm, F1.3, DC Auto Iris Lens, IR Corrected
HLD5V50DNL	5.0-50 mm, F1.6, DC Auto Iris Lens, IR Corrected
<b>Housing and Mounts</b>	
HBC5WT	Wall/ceiling mount bracket

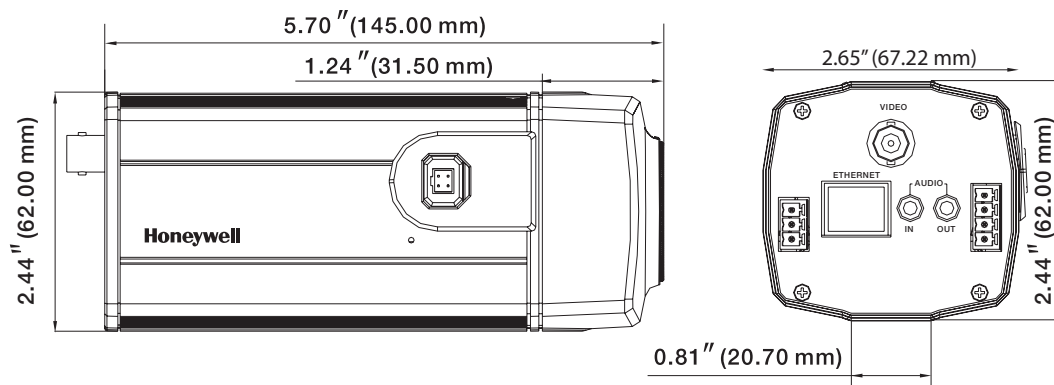

Ordering	
HCD554IPX	EQUIP Series 1/3" CCD High Resolution True Day/Night Camera with DSP, 540 TVL, 12 VDC/24 VAC or PoE IEEE 802.3 af, PAL

**NOTE:** Honeywell reserves the right, without notification, to make changes in product design or specifications.

### Honeywell Security

Post Office Box 18530  
 LOB Building 08, Office 199  
 Jebel Ali  
 Dubai  
 United Arab Emirates  
 Tel: 971-04-881-5506  
 Fax: 971-04-881-6220  
[www.honeywell.com/security/me](http://www.honeywell.com/security/me)

HVS-HCD554IPX-ME-01(0508)DS-COE  
 May 2008  
 © 2008 Honeywell International Inc.